

Product Name: **Spring Change Assistance Kit**  
 Product Description: Spring Change Assistance Kit  
 Product Number: TS-0550-3094  
 Document Version: V1.00 Rev A



**IMPORTANT NOTES ON YOUR SPRING CHANGING TOOL**

- Turbosmart accepts NO responsibility whatsoever for incorrect use of this product which is potentially hazardous and can cause serious personal injury.
- Read and understand the instructions for you individual product before attempting to use this tool.

**RECOMMENDATIONS**

- **Turbosmart recommends that your Products be assembled by an appropriately qualified technician**

**KIT CONTENTS**

Please check that the following items have been provided in your Turbosmart Spring Change Tool packaging

Part	Description	Use
1	Turbosmart Spring Changer	Main unit
4	Turbosmart Sticker	Turbosmart sticker

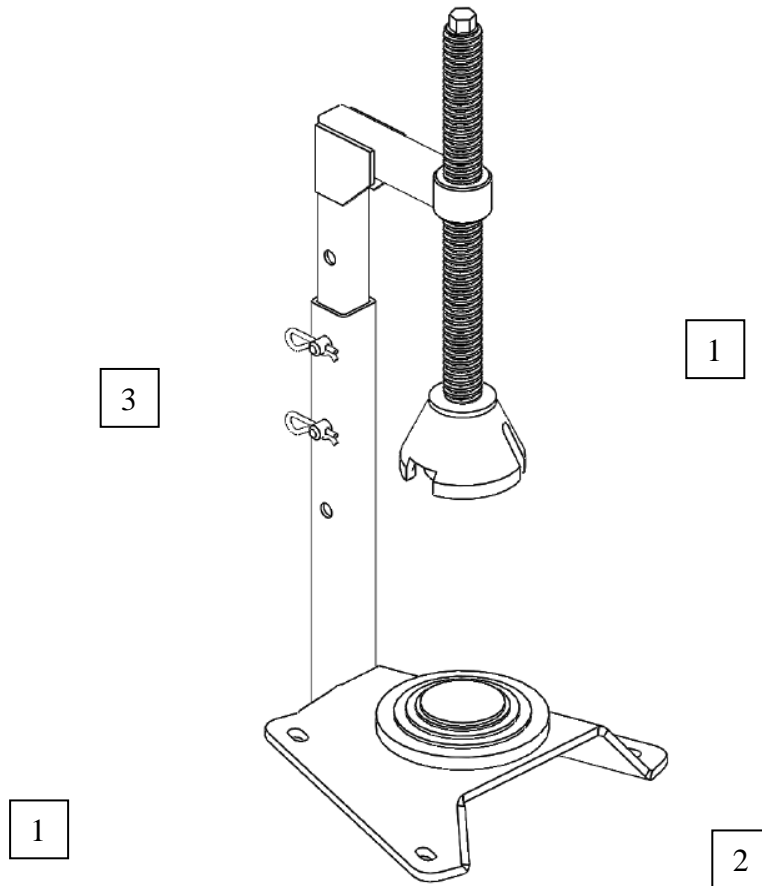

**Figure 1 - Kit Contents**

**TOOLS REQUIRED**

- 12mm spanner/socket and driver

## ABOUT YOUR SPRING CHANGER

The Spring changing tool by Turbosmart is designed to be compatible with most Turbosmart products that requires changing the springs for tuning purposes, quick release pins allow quick height adjustments to suit smaller or larger products

Benefits include:

- Concentric base plate
- Quick release pins for height adjustment
- Non-marring head
- Table mountable or Vice

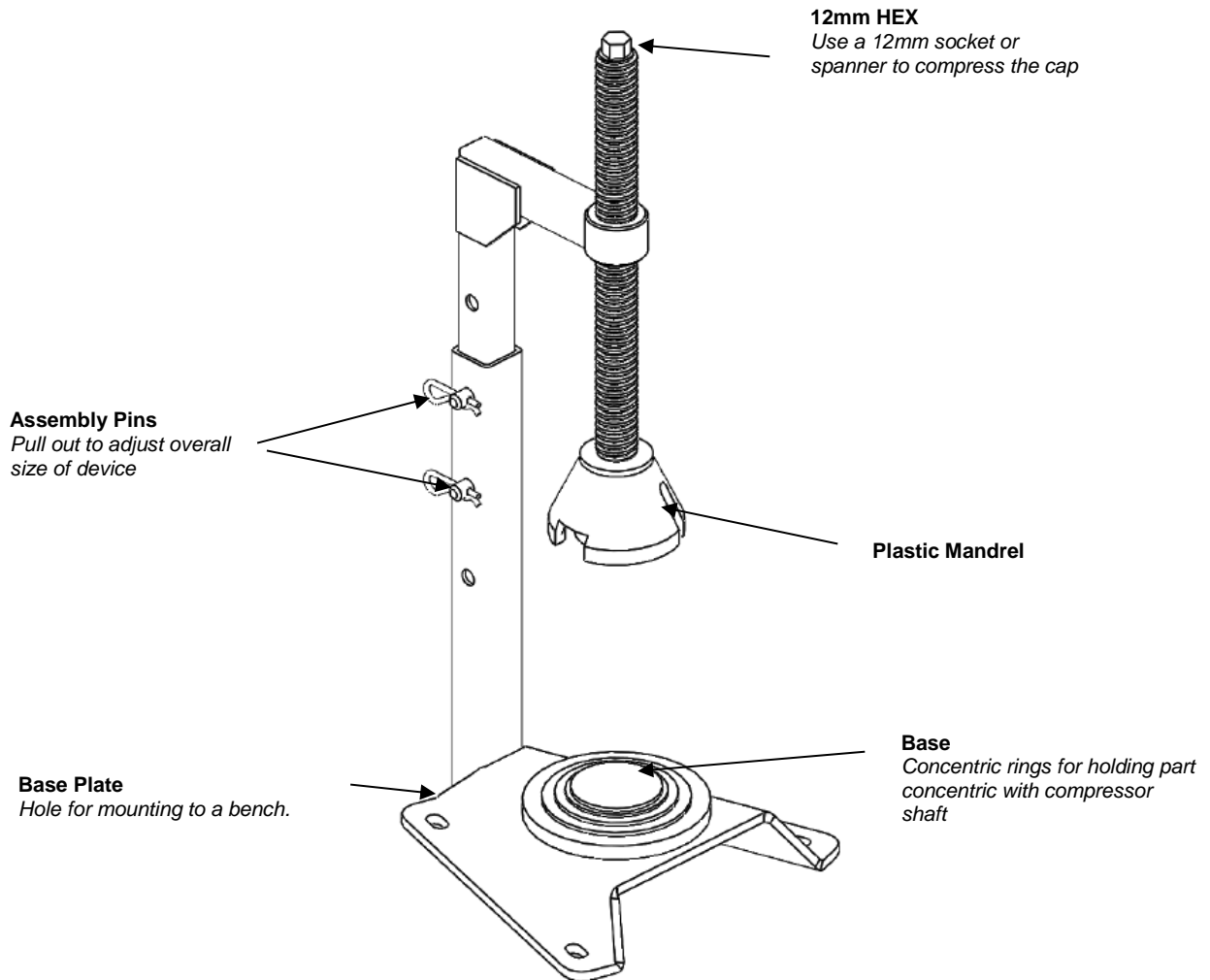

Figure 2 – Spring Changer Overview

# FITTING YOUR KOMPACT SERIES BOV

## 1 Mounting the Spring Changer

The base plate of the spring changer has four holes to be used for mounting to a solid workbench for the best rigidity.

The spring changer can also be held in a vice by the upright in a manner that is most suits the user most. When using a vice ensure the jaws do not extend into the work area to avoid damage to the product.

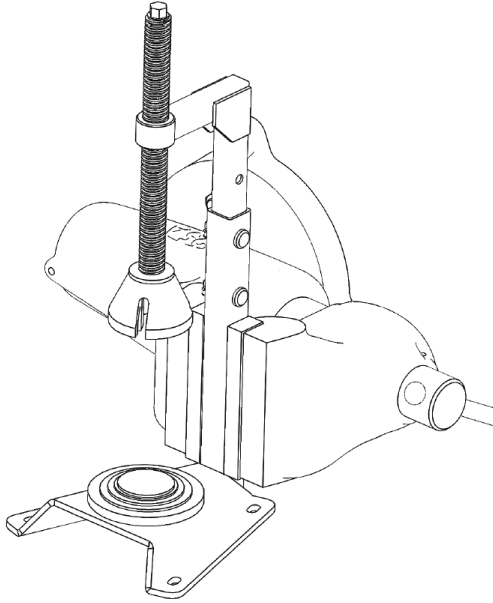

## 2 Set Size of Tool

Remove the R clips from the pins in the stem of tool, remove the pins and slide the head up and down to the desired position and reinsert the pins and R clips. Have the tool as short as possible whilst maintaining enough room for the springs to extend.

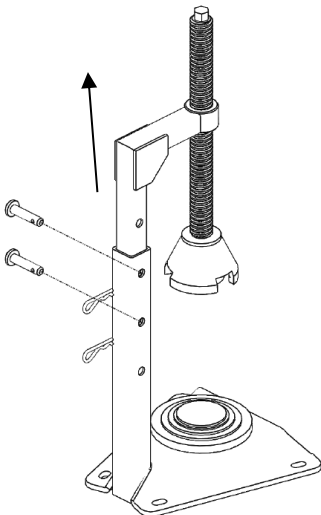

## 3 Set Part and Compress Cap

Set part on the concentric base, the different levels of the base will hold the part centred with the compression screw.

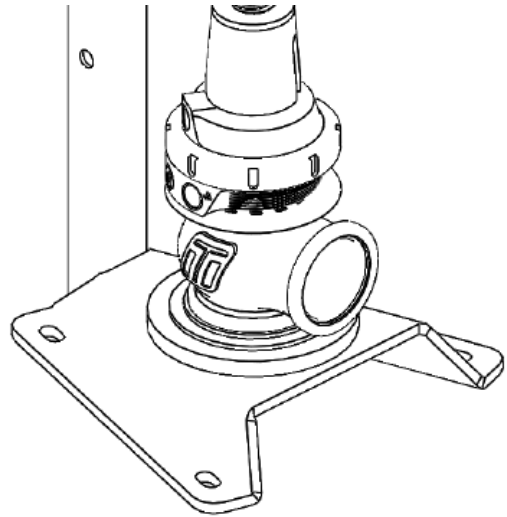

Ensure head is placed into the compression screw with the supplied washer between. Screw the compression screw down using a 12mm spanner.

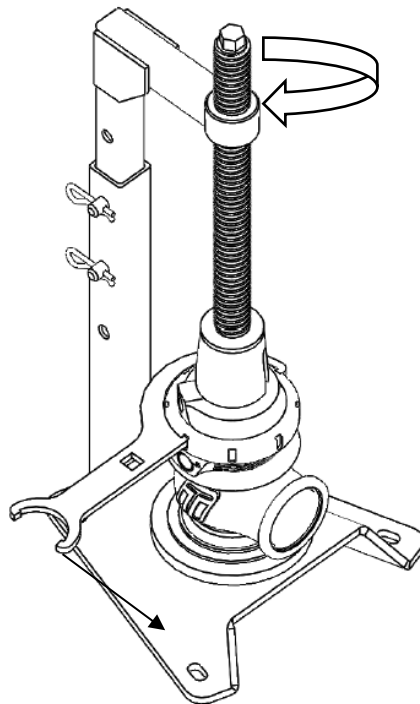

**NOTE!**  
Use individual product instructions for how to remove and assemble the spring and cap.

## 2

### Release Spring Tension

Once the fixture has been released from the cap hold the cap of the product and start unwinding the compression screw holding your hand in a way that prevents ejection of the spring out the side. Once the spring tension has been released, change the spring to your desired configuration and reverse the steps ensuring the cap is aligned correctly on the product during compression.

#### NOTE!

Use individual product instructions for how to remove and assemble the spring and cap.

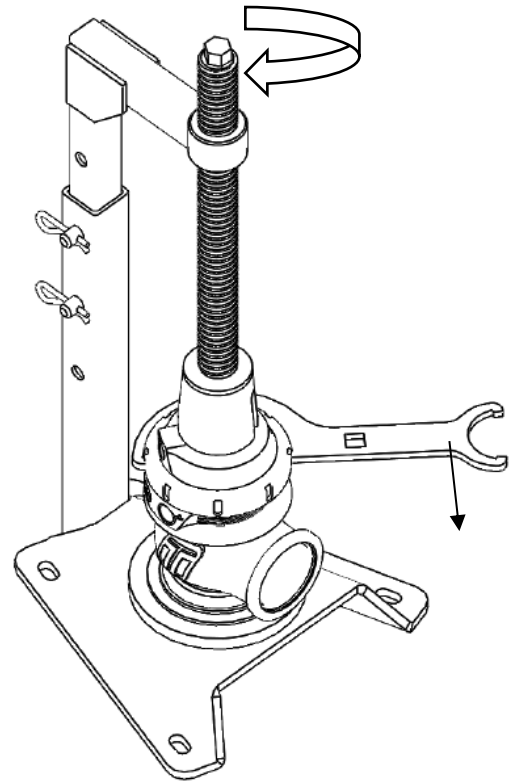
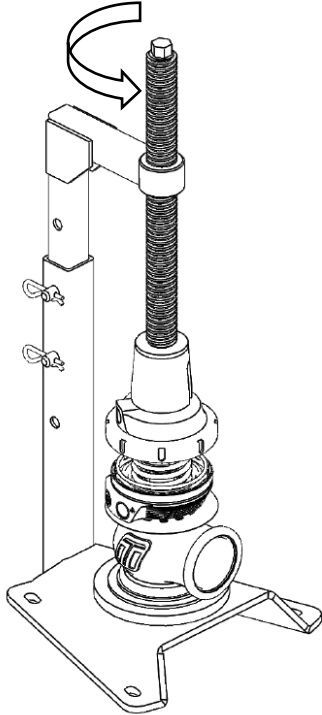

**CAUTION!**  
Beware on pinching.