

# HDS-18EA

**babco**

## Alignment Lifts

SKU# 5175969

18,000-lb. Capacity / Four-Post Alignment Lift / Includes Turnplates and Slip Plates

Questions? Contact Babco's Sales Team

info@babco.ca | 1-800-661-5313

## A Four-Post Truck Lift for Every Alignment Application

You're now looking at the largest-capacity [alignment lift](#) we make. 18,000 lbs. of lifting power is made possible by manufacturing our cable sheaves, base columns and base plates to be as robust and durable as possible. Of course, it's all 100% ALI Certified for your safety. When you need to align truck wheels, from light-duty all-terrain trucks all the way to massive dumpster trucks and smaller flat-beds, BendPak's free-floating slip plates and galvanized steel turn plates make the job easy to get done right the first time.

## Features

- 18,000-lb. lifting capacity
- CE Approved and Certified. Meets or exceeds the standards prescribed by European Standard EN-1493
- Multi-caster slip plates
- Spring-loaded automatic safety locks
- Supersized 12" diameter cable sheaves
- Four stainless steel lifting cables
- Grease nipples on every sheave and axle
- Single hydraulic under-runway cylinder
- Integrated hydraulic flow restrictor
- Durable powder coat finish
- Push-button pneumatic lock release
- Secondary lock system on constant guard
- Enclosed cables, airlines, safety latches
- Multiple adjustable locking positions
- Maintenance-free power system
- Conveniently located controls
- 12" x 12" base plates
- Non-skid runways
- Optional rolling jacks available

Note: An air supply (minimum 30 psi / 3 CFM) is required for the safety-lock mechanisms to disengage. It is solely the responsibility of the end-user to provide, install and maintain the air supply.

Not all BendPak lift models meet the standards as prescribed by ANSI/ALI ALCTV-2011 or ANSI/UL 201. Consult [www.autolift.org](http://www.autolift.org) for complete listings or contact BendPak via [contact@bendpak.com](mailto:contact@bendpak.com).



### A Truck Lift for Every Alignment Application

BendPak's largest-capacity alignment lift easily accommodates vehicles up to 18,000 lbs. Of course, it still services smaller sports cars and race cars without a problem. If your shop is busy and can't afford the space for multiple lifts, you'll need the extra lifting power to be ready for those larger trucks and SUVs. The HDS18EA offers the same safety features and rugged design as every other car lift we make, from the aircraft-quality steel cables and enhanced cable sheaves to the adjustable locking heights and slack-cable secondary lock system. You'll also enjoy the best warranty money can buy, which makes this car lift is the very best value of any alignment lift, anywhere.

### Slip plates

Our rear-seated, free-floating slip plates let you perform wheel alignments on heavy trucks while keeping vehicle suspensions relaxed, securely fitted on the slip plates. This is the best way to perform wheel alignments because it eliminates potential flex and loss of pressure in rear tire walls as a result of old-fashioned alignments that require individual wheel jacking.

### Deluxe Turnplates

Aluminum-alloy construction turn plates are easily positioned using BendPak's turn plate pockets. Larger and more robust than our previous slip-plate design, they're also lighter in construction and feature dual "popsicle gap stops" for your convenience. Angled steel lock pins conveniently hold the plate in place when you want to use your machine strictly as a maintenance or storage lift.

# Specifications

**babco**

Model	HDS-14LSX	HDS-14LSXE	HDS-18E
Style	Alignment Lift	Alignment Lift / Extended	Alignment Lift
SKU#	5175171	5175172	5175969
Lifting Capacity	14,000 lbs. (6,350 kg)	14,000 lbs. (6,350 kg)	18,000 lbs. (8,165 kg)
A - Min. Runway Height	7-5/8" (192 mm)	7-5/8" (192 mm)	10.5" (267 mm)
B - Max. Rise	70" (1,778 mm)	70" (1,778 mm)	60" (1,524 mm)
C - Max. Lifting Height	77-5/8" (1,970 mm)	77-5/8" (1,970 mm)	70.5" (1,791 mm)
D - Overall Width	130" (3,301mm)	130" (3,301mm)	154" (3,912 mm)
E - Outside Length	213" (5,408 mm)	243" (6,170 mm)	257" (6,528 mm)
F - Overall Length	241" (6,131 mm)	271" (6,893 mm)	297" (7,544 mm)
G - Height of Columns	95" (2,413 mm)	93" (2,362 mm)	93" (2,362 mm)
H - Width Between Columns	120" (3,046 mm)	120" (3,046 mm)	134" (3,404 mm)
I - Drive-Thru Clearance	76.5" (1,943 mm)	76.5" (1,943 mm)	76.5" (1,943 mm)
J - Runway Width	20" (508 mm)	20" (508 mm)	22" (559 mm)
K - Length of Runways	199" (5,054 mm)	229" (5,816 mm)	263" (6,680 mm)
L - Width Between Runways	37.5" (952 mm) - 51" (1,295 mm)	37.5" (952 mm) - 51" (1,295 mm)	38" (965 mm) - 56" (1,422 mm)
M - Min. 4-Wheel Alignment	89" (2,261 mm)	89" (2,261 mm)	83" (2,108 mm)
N - Max. 4-Wheel Alignment	156" (3,962 mm)	156" (3,962 mm)	138" (3,505 mm)
O - Max. 2-Wheel Alignment	182" (4,623 mm)	212" (5,385 mm)	211" (5,359 mm)
Min. Wheelbase @ Capacity	140" (3,556 mm)	165" (4,191 mm)	185" (4,699 mm)
Min. Wheelbase @ 75%	120" (3,048 mm)	140" (3,556 mm)	160" (4,064 mm)
Min. Wheelbase @ 50%	100" (2,540 mm)	115" (2,921 mm)	135" (3,429 mm)
Min. Wheelbase @ 25%	80" (2,032 mm)	95" (2,413 mm)	110" (2,794 mm)
Locking Positions	13	13	9
Lock Spacing	every 4" (102 mm)	every 4" (102 mm)	every 4" (102 mm)
Lifting Time	60 seconds	60 seconds	60 seconds
Motor	220 VAC / 60 Hz. / 1 Ph	220 VAC / 60 Hz. / 1 Ph	220 VAC / 60 Hz. / 1 Ph

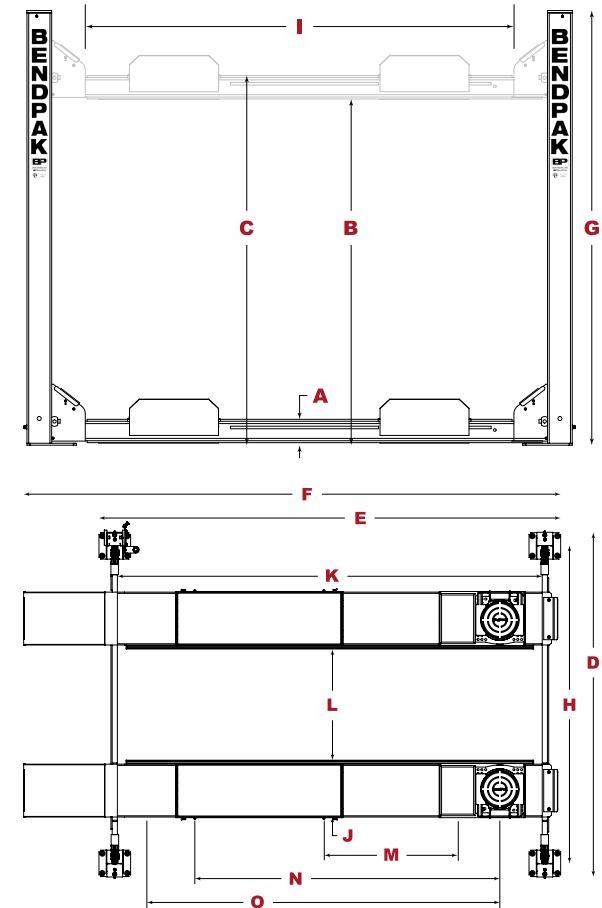

Note: An air supply (minimum 30 psi / 3 CFM) is required for the safety-lock mechanisms to disengage. It is solely the responsibility of the end-user to provide, install and maintain the air supply.

Not all BendPak lift models meet the standards as prescribed by ANSI/ALI ALCTV-2011 or ANSI/UL 201. Consult [www.autolift.org](http://www.autolift.org) for complete listings or contact BendPak via [contact@bendpak.com](mailto:contact@bendpak.com).