



Lube Level Maintainer

Models LM500/LM500-TF

Installation Instructions

Warranty - A limited warranty on materials and workmanship is given with this Murphy product. A copy of the warranty may be viewed or printed by going to <http://www.fwmurphy.com/warranty>.



BEFORE INSTALLING THIS MURPHY PRODUCT:

- A visual inspection of this product for damage during shipping is recommended before installation.
- It is your responsibility to ensure that qualified mechanical and electrical technicians install this product.
- Disconnect all electrical power to the machine.
- Make sure machine cannot operate during installation.
- Follow all safety warnings of the machine manufacturer.
- Read and follow all installation instructions.
- Please contact Enovation Controls immediately if you have any questions.

Table of Contents

General Information	1
Description	1
Dimensions	1
Range of the Snap-Switch.....	2
Test Feature.....	2
Thumb-Valve™ Operation.....	3
LM500 Series Flow Rates	3
Service Parts (Specify part number)	4
Hose Kit (P/N 15000355)	4
Vent Fittings Kit (P/N 15000954).....	4
Fittings Kit (P/N 15000943).....	4
Bubble Lens Kit (P/N 15000532).....	4
Typical Installation	5
Mount the LM500	5
Pipe Bracket Mount (PM) (P/N 15000518).....	5
Universal Bracket Mount (UB) (P/N 15000519).....	6
Base Mounting.....	6
Crankcase (Oil Pan) Mounting.....	6
Connect Fittings and Hoses	7
Connect LM500 to Oil Supply Tank.....	8
LM500 Typical Installation Shown.....	8
Specifications	9

THIS PAGE INTENTIONALLY LEFT BLANK

General Information

Description

The Murphy LM500 model maintains the crankcase oil level of an engine, pump or compressor. Adjusted to the correct running oil level, the LM500 will replenish oil as it is used. The low level switch will alarm and/or shut down the equipment if the supply oil is lost and the equipment continues to use oil. The LM500-TF model includes a test feature that confirms both the float and switch are operating correctly with a single press of the test button.

Dimensions

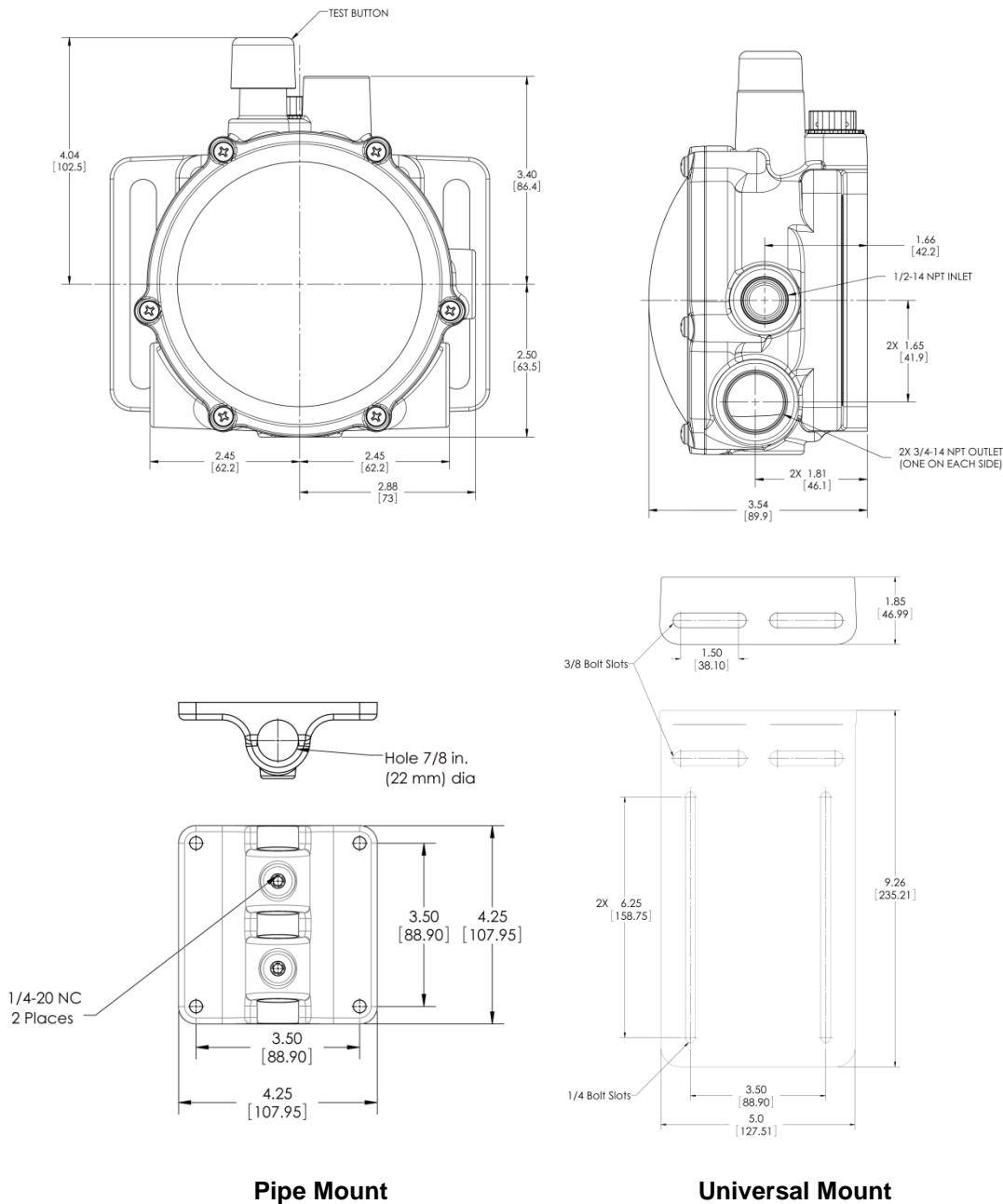

Pipe Mount

Universal Mount

Range of the Snap-Switch

This illustration shows the LM500 dial and the operating range of the switch. If level is within the designated zones, the switch will activate.

The switch activates approximately 1/4 in. (6 mm) from the bottom of the low zone. If the level continues to drop into the low-low zone, a shutdown will occur.

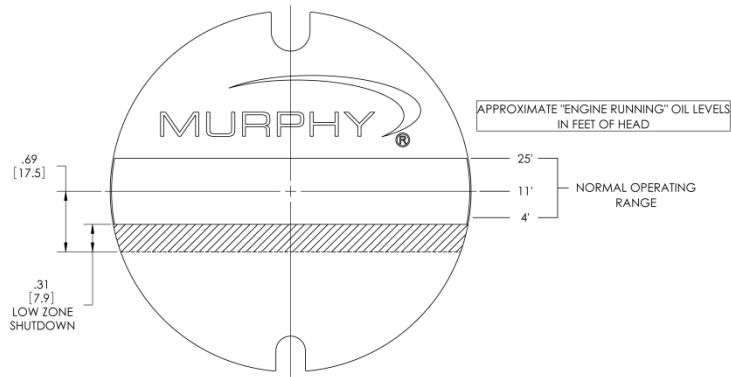

NOTE: Color zones on dial face show approximate normal operating zones. Actual conditions may vary depending upon operating characteristics of the engine. Placement of the LM500 according to the above instructions will compensate for these conditions.

Test Feature

The form C (3-wire) contact allows a controller/annunciator to be wired as a closed loop system, resulting in a reliable fault-sensitive circuit.

NOTE: Holding test button for a prolonged period of time could cause crank case to overfill.

Thumb-Valve™ Operation

As the equipment uses oil, the float falls, providing immediate level compensation. At the FULL position, the float holds the valve closed. If the clean oil supply is depleted and oil level continues to fall, the low level switch will operate an alarm or equipment shutdown.

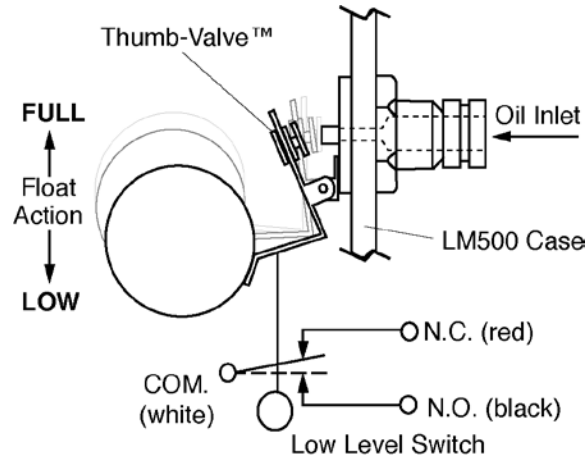

LM500 Series Flow Rates

LM500 Series Flow Rates are based on SAE 40 motor oil @2 ft. head pressure. Friction losses due to piping are not considered.

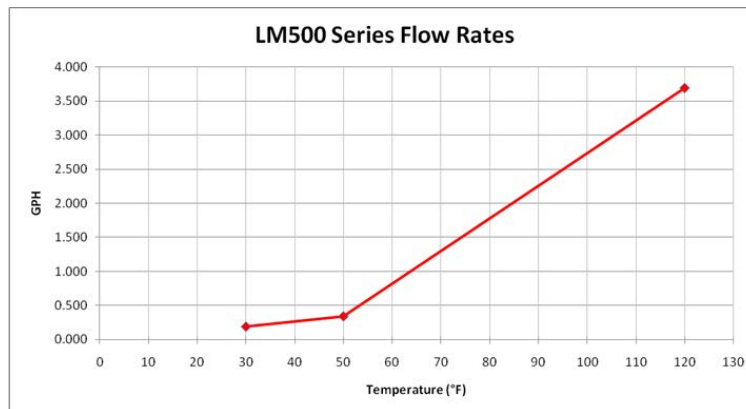

Service Parts (Specify part number)

Description	Part Number
Vent Fittings kit	15000954
Hose kit	15000355
1/2 NPT x 1/2 in. hose barbed fitting	89080801
3/4 NPT x 1/2 in. hose barbed fitting	89081001
Pipe Bracket kit	15000518
Universal Flange kit	15000519

Hose Kit (P/N 15000355)

Quantity	Description
1	1/2 in. (13 mm) I.D. x 3 ft. (914 mm) long hose
1	1 in. (25 mm) I.D. x 3 ft. (914 mm) long hose
2	1/2 in. (13 mm) worm gear clamp
2	1 in. (25 mm) worm gear clamp
2	1/2 NPT x 1/2 in. (13 mm) barbed fitting

Vent Fittings Kit (P/N 15000954)

Quantity	Description
1	Tubing vent
1	1/4 x 1/4 NPT connector

Fittings Kit (P/N 15000943)

Quantity	Description
1	Tubing vent
1	Hose barb, 1/2 NPT to 1/2 Hose
1	Hose barb, 1 in. I.D. HOSEX 3/4 NPT
1	Connector, 1/4 T x 1/2

Bubble Lens Kit (P/N 15000532)

Quantity	Description
1	Dial
1	O-ring, 0.139 C/S, 4.359 ID
6	Shoulder screw, #8-32 x 0.3125
1	Bubble lens

Typical Installation

Mount the LM500

NOTE: Mount the LM500 as close as possible to the crankcase.



CAUTION: Excessive vibration can cause overflow. Be sure mounting brackets are supported.

The following instructions are based on the use of the pipe and universal mounting brackets shown on page 1.

Pipe Bracket Mount (PM) (P/N 15000518)

1. Mount a nominal 1/2 inch (13 mm) diameter pipe to the base of the engine.
2. Install the pipe bracket to the LM500 using the supplied fasteners, two 1/4-20 UNC x 1 inch bolts; nuts and lock washers.
3. Slip the LM500 onto the pipe and install the two adjustment bolts. Each bolt consists of a 1/4-20 UNC x 1 inch bolt, nuts and lock washers. **DO NOT** tighten the adjustment screws too tight as height adjustment might be needed later during the operation. Refer to Connect Fittings and Hoses, for more information regarding height adjustment of the LM500 in alignment with the oil level in the crankcase.

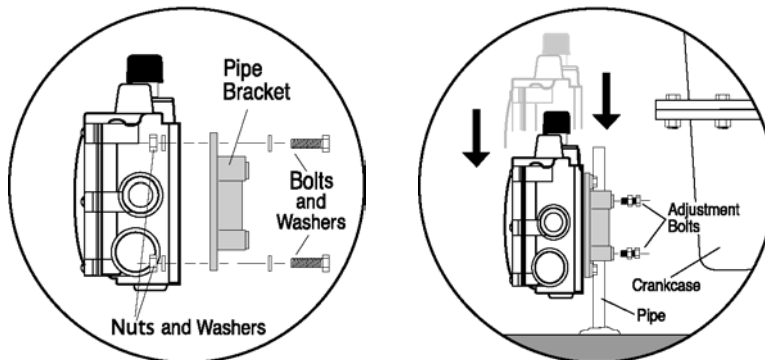

Universal Bracket Mount (UB) (P/N 15000519)

The universal bracket has two mounting methods: base mounting or pan mounting.

Base Mounting

1. Install the universal bracket to the base as shown using two split lock washers and two 5/16 inch diameter bolts or others as necessary.
2. Mount the LM500 to the universal bracket using the supplied fasteners, four 1/4-20 UNC x 1-1/4 inch (32 mm) bolts; flat and lock washers. DO NOT tighten the adjustment screws too tight as you will have to adjust the LM500 later in the installation process. Refer to Connect Fittings and Hoses for information regarding height adjustment of the LM500 in alignment with the oil level in the crankcase.

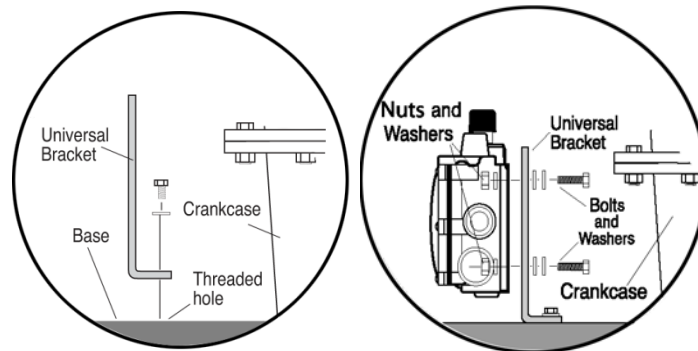

Crankcase (Oil Pan) Mounting

1. Install the universal bracket to the crankcase using the existing crankcase bolts. Crankcase bolt diameter must be no larger than 7/16 inch (11 mm).

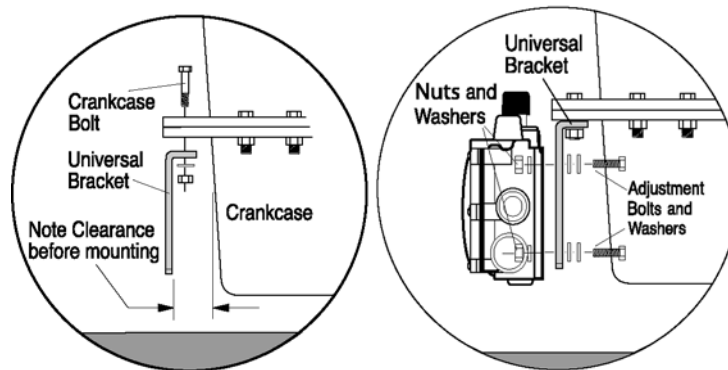

NOTE: Check clearance between crankcase and mounting bracket before installing the mounting bracket. If space between the crankcase and mounting bracket is narrow, attach LM500 to mounting bracket prior to installation on crankcase.

2. Mount the LM500 to the universal bracket using the supplies fasteners, four 1/4-20 UNC x 1-1/4 inch bolts, flat and lock washers. DO NOT tighten the adjustment bolts too tight as height adjustment might be needed later during the operation.

3. Refer to Connect Fittings and Hoses for information regarding height adjustment of the LM500 in alignment with the oil level in the crankcase.

Connect Fittings and Hoses

The following instructions are based on the Murphy hose kit.

1. Install the LM500 fittings in their proper locations.

NOTE: Apply a sealant such as Teflon[®] to all threaded connections.

2. Attach the 1 inch (25 mm) diameter, flexible monitoring hose to the crankcase and the monitoring port on the LM500.

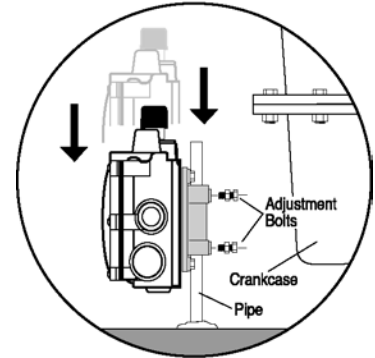

CAUTION: The hose must slope slightly downward from the LM500 and **MUST NOT** have any droops or low spots.

NOTE: If the drain plug on the crankcase is used for the connection, it is recommended that a T-fitting be installed to allow draining of the crankcase for service.

3. Install the 1/2 inch (13 mm) I.D. x 3 ft (914 mm) hose to the vent connection on the LM500 and to the vent connection on the crankcase. **The vent connection on the crankcase must be well above the regulated oil level.** All hoses must be clear of obstructions, valleys or dips that could create liquid traps or gas/air pockets. The vent and crankcase connections should be as straight as possible.
BEFORE CONTINUING, VERIFY THAT ALL HOSE CLAMPS ARE TIGHT.
4. Fill the crankcase to the proper oil level.



IMPORTANT: With the engine running and warm, loosen the mounting bracket adjustment bolts and adjust the LM500 so that the oil level in the sight gage is aligned with the middle of the green bar on the dial.

5. Tighten the adjustment bolts securely.

Connect LM500 to Oil Supply Tank

1. Remove the plug from the oil inlet connection. Be sure the removable screen inside the connection is clear of debris. Install the oil inlet connection.
2. Connect a 1/2 inch I.D. (13 mm) or larger hose to the oil inlet fitting on the LM500 and to the shut-off valve on the oil supply tank. Recommended minimum height above the LM500 is 2 feet. (0.6 m); maximum 25 feet (7.7 m). The hose must maintain a downward slope and not have low spots or droops. Maximum head pressure rating is 9.50 psi or 25 foot oil (head pressure).
3. Before filling the supply tank with oil, be sure the tank is clean and dry and the shut-off valve is closed. Also, be sure all hoses and clamps are tight. Fill the tank with CLEAN oil.



WARNING: Overfill condition can be caused by excessive inlet pressure and/or improper vent-to-crankcase installation.

4. After oil supply tank is full, open the shut-off valve.
5. Make the proper electrical connections for the application.

LM500 Typical Installation Shown



WARNING: Perform this installation using appropriate protection. Trapped air and hot oil may cause burns.

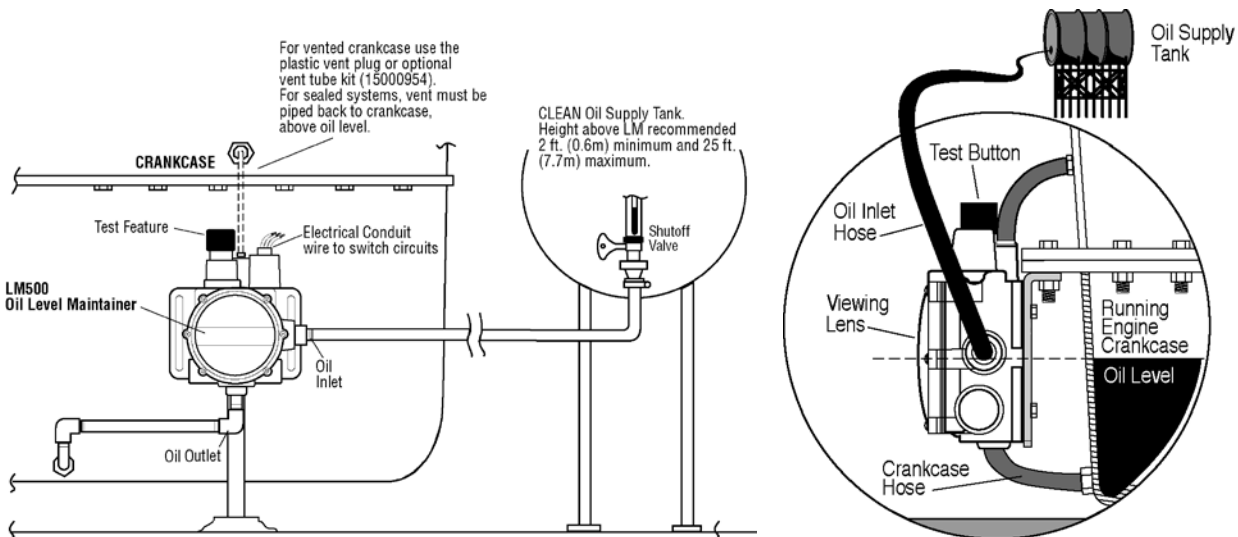

Specifications

Crankcase Balance Vent Connection: 1/2 NPTF (top)

Inlet Connection: 1/2 NPTF removable screen (side)

Outlet Connection: 2 x 3/4 NPTF (side)

1 x 3/4 NPTF (bottom)

Thumb-Valve™ Material: Viton

Snap-switch: SPDT rating 10 A, 125 VAC; 0.5 A, 125 VDC; 10 A, 30 VDC

Wire leads: 18 AWGT x 14 in. +/- 2 in. (355 mm) length

Conduit Connection: 1/2 inch conduit (female, top). (Refer to 00-02-0735 Teflon Tape Wrapping Technique)

Case: Die-cast aluminum

Lens: Clear frog eye non-staining, high impact, high temperature polycarbonate; UV and heat stabilized

Dial: High visibility white background with solid green band for normal level indication

Maximum Inlet Pressure: 9.50 psi/25 ft. oil (head pressure)

Maximum Differential: 2 in. (51mm) between running and stopped

Maximum Ambient Temperature: 250°F (121°C)

Float: 304 Stainless Steel

Flow Rates: Refer to Flow Rate Chart

